



**Robert Bosch GmbH**  
Power Tools Division  
70745 Leinfelden-Echterdingen  
Germany

[www.bosch-pt.com](http://www.bosch-pt.com)

1 609 929 S25 (2008.12) T / 219 UNI

## GSC 10,8 V-LI Professional



<b>de</b> Originalbetriebsanleitung	<b>el</b> Πρωτότυπο οδηγιών χρήσης	<b>sr</b> Originalno uputstvo za rad
<b>en</b> Original instructions	<b>tr</b> Orijinal işletme talimatı	<b>sl</b> Izvirna navodila
<b>fr</b> Notice originale	<b>pl</b> Instrukcja oryginalną	<b>hr</b> Originalne upute za rad
<b>es</b> Manual original	<b>cs</b> Původní návod k používání	<b>et</b> Algupärane kasutusjuhend
<b>pt</b> Manual original	<b>sk</b> Pôvodný návod na použitie	<b>lv</b> Instrukcijas oriģinālvalodā
<b>it</b> Istruzioni originali	<b>hu</b> Eredeti használati utasítás	<b>lt</b> Originali instrukcija
<b>nl</b> Oorspronkelijke gebruiksaanwijzing	<b>ru</b> Оригинальное руководство по эксплуатации	
<b>da</b> Original brugsanvisning	<b>uk</b> Оригінальна інструкція з експлуатації	
<b>sv</b> Bruksanvisning i original	<b>ro</b> Instrucțiuni originale	
<b>no</b> Original driftsinstruks	<b>bg</b> Оригинална инструкция	
<b>fi</b> Alkuperäiset ohjeet		



3 |

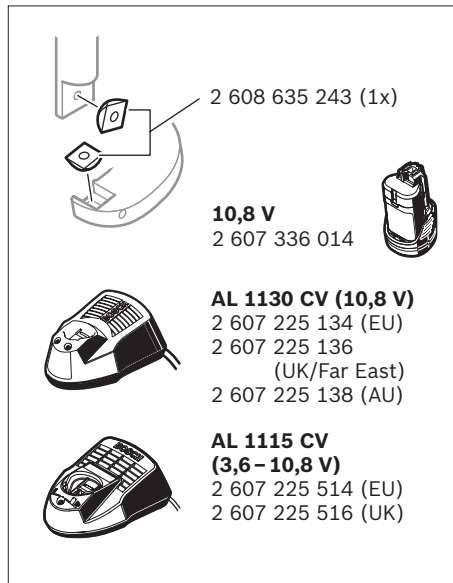
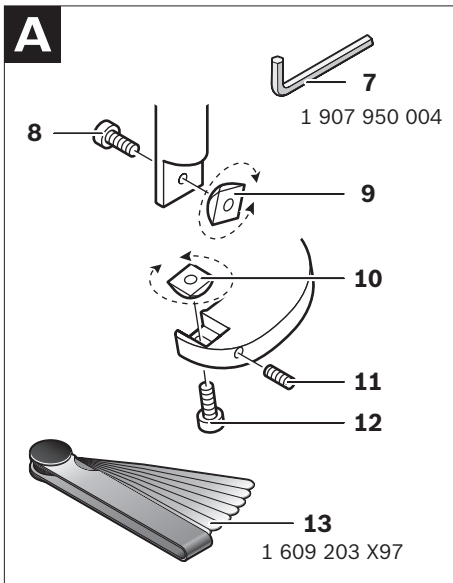
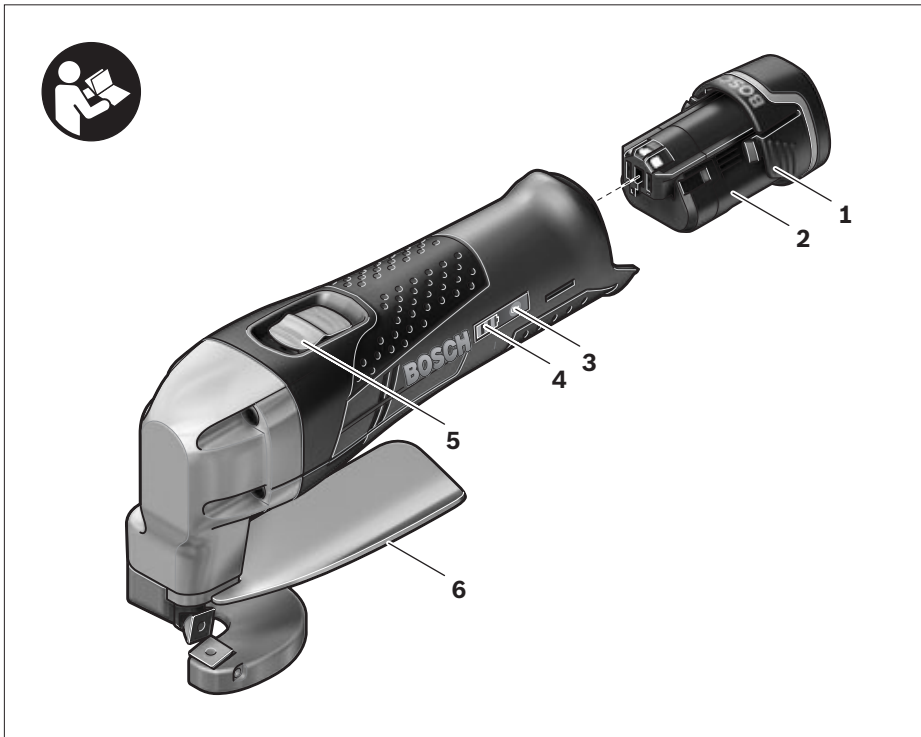

## Safety Notes

### General Power Tool Safety Warnings

**⚠ WARNING** Read all safety warnings and all instructions. Failure to follow the warnings and instructions may result in electric shock, fire and/or serious injury.

Save all warnings and instructions for future reference.

The term “power tool” in the warnings refers to your mains-operated (corded) power tool or battery-operated (cordless) power tool.

#### 1) Work area safety

- a) **Keep work area clean and well lit.** Cluttered or dark areas invite accidents.
- b) **Do not operate power tools in explosive atmospheres, such as in the presence of flammable liquids, gases or dust.** Power tools create sparks which may ignite the dust or fumes.
- c) **Keep children and bystanders away while operating a power tool.** Distractions can cause you to lose control.

#### 2) Electrical safety

- a) **Power tool plugs must match the outlet. Never modify the plug in any way. Do not use any adapter plugs with earthed (grounded) power tools.** Unmodified plugs and matching outlets will reduce risk of electric shock.
- b) **Avoid body contact with earthed or grounded surfaces, such as pipes, radiators, ranges and refrigerators.** There is an increased risk of electric shock if your body is earthed or grounded.
- c) **Do not expose power tools to rain or wet conditions.** Water entering a power tool will increase the risk of electric shock.
- d) **Do not abuse the cord. Never use the cord for carrying, pulling or unplugging the power tool. Keep cord away from heat, oil, sharp edges and moving parts.** Damaged or entangled cords increase the risk of electric shock.

e) **When operating a power tool outdoors, use an extension cord suitable for outdoor use.** Use of a cord suitable for outdoor use reduces the risk of electric shock.

f) **If operating a power tool in a damp location is unavoidable, use a residual current device (RCD) protected supply.** Use of an RCD reduces the risk of electric shock.

#### 3) Personal safety

a) **Stay alert, watch what you are doing and use common sense when operating a power tool. Do not use a power tool while you are tired or under the influence of drugs, alcohol or medication.**

A moment of inattention while operating power tools may result in serious personal injury.

b) **Use personal protective equipment.**

**Always wear eye protection.** Protective equipment such as dust mask, non-skid safety shoes, hard hat, or hearing protection used for appropriate conditions will reduce personal injuries.

c) **Prevent unintentional starting. Ensure the switch is in the off-position before connecting to power source and/or battery pack, picking up or carrying the tool.** Carrying power tools with your finger on the switch or energising power tools that have the switch on invites accidents.

d) **Remove any adjusting key or wrench before turning the power tool on.** A wrench or a key left attached to a rotating part of the power tool may result in personal injury.

e) **Do not overreach. Keep proper footing and balance at all times.** This enables better control of the power tool in unexpected situations.

f) **Dress properly. Do not wear loose clothing or jewellery. Keep your hair, clothing and gloves away from moving parts.**

Loose clothes, jewellery or long hair can be caught in moving parts.

## 14 | English

- g) If devices are provided for the connection of dust extraction and collection facilities, ensure these are connected and properly used.** Use of dust collection can reduce dust-related hazards.
- 4) Power tool use and care**
- a) Do not force the power tool. Use the correct power tool for your application.** The correct power tool will do the job better and safer at the rate for which it was designed.
- b) Do not use the power tool if the switch does not turn it on and off.** Any power tool that cannot be controlled with the switch is dangerous and must be repaired.
- c) Disconnect the plug from the power source and/or the battery pack from the power tool before making any adjustments, changing accessories, or storing power tools.** Such preventive safety measures reduce the risk of starting the power tool accidentally.
- d) Store idle power tools out of the reach of children and do not allow persons unfamiliar with the power tool or these instructions to operate the power tool.** Power tools are dangerous in the hands of untrained users.
- e) Maintain power tools. Check for misalignment or binding of moving parts, breakage of parts and any other condition that may affect the power tool's operation. If damaged, have the power tool repaired before use.** Many accidents are caused by poorly maintained power tools.
- f) Keep cutting tools sharp and clean.** Properly maintained cutting tools with sharp cutting edges are less likely to bind and are easier to control.
- g) Use the power tool, accessories and tool bits etc. in accordance with these instructions, taking into account the working conditions and the work to be performed.** Use of the power tool for operations different from those intended could result in a hazardous situation.
- 5) Battery tool use and care**
- a) Recharge only with the charger specified by the manufacturer.** A charger that is suitable for one type of battery pack may create a risk of fire when used with another battery pack.
- b) Use power tools only with specifically designated battery packs.** Use of any other battery packs may create a risk of injury and fire.
- c) When battery pack is not in use, keep it away from other metal objects, like paper clips, coins, keys, nails, screws or other small metal objects, that can make a connection from one terminal to another.** Shorting the battery terminals together may cause burns or a fire.
- d) Under abusive conditions, liquid may be ejected from the battery; avoid contact. If contact accidentally occurs, flush with water. If liquid contacts eyes, additionally seek medical help.** Liquid ejected from the battery may cause irritation or burns.
- 6) Service**
- a) Have your power tool serviced by a qualified repair person using only identical replacement parts.** This will ensure that the safety of the power tool is maintained.

### Safety Warnings for Cordless Sheet Metal Shears

- ▶ **Secure the workpiece.** A workpiece clamped with clamping devices or in a vice is held more secure than by hand.
  - ▶ **Always wait until the machine has come to a complete stop before placing it down.** The tool insert can jam and lead to loss of control over the power tool.
  - ▶ **Do not open the battery.** Danger of short-circuiting.
-  **Protect the battery against heat, e.g., also against continuous sun irradiation and fire.** There is danger of explosion.
- ▶ **In case of damage and improper use of the battery, vapours may be emitted. Provide for fresh air and seek medical help in case of complaints.** The vapours can irritate the respiratory system.

- ▶ **When the battery is defective, liquid can escape and come into contact with adjacent components. Check any parts concerned.** Clean such parts or replace them, if required.
- ▶ **Use the battery only in conjunction with your Bosch power tool.** This measure alone protects the battery against dangerous overload.

## Functional Description



**Read all safety warnings and all instructions.** Failure to follow the warnings and instructions may result in electric shock, fire and/or serious injury.

While reading the operating instructions, unfold the graphics page for the machine and leave it open.

## Intended Use

The power tool is intended for cutting sheet metals without loss due to metal chips. It is suitable for curved and straight cuts.

## Product Features

The numbering of the product features refers to the illustration of the machine on the graphics page.

- 1 Battery unlocking button
- 2 Battery
- 3 Button for charge-control indicator
- 4 Battery charge-control indicator
- 5 On/Off switch
- 6 Chip deflector
- 7 Allen key
- 8 Fastening screw for upper cutter
- 9 Upper cutter
- 10 Bottom cutter
- 11 Adjustment screw, bottom cutter
- 12 Fastening screw for bottom cutter
- 13 Setting gauge\*

**\*Accessories shown or described are not part of the standard delivery scope of the product. A complete overview of accessories can be found in our accessories program.**

## Technical Data

Cordless Sheet Metal Shears	GSC 10,8 V-Li Professional	
Article number	3 601 J26 1..	
Rated voltage	V=	10.8
Stroke rate at no load $n_0$	min <sup>-1</sup>	3600
Max. steel sheet cutting capacity*	mm	1.3
Smallest curve radius	mm	15
Weight according to EPTA-Procedure 01/2003	kg	1.4

\* to 400 N/mm<sup>2</sup> with reference to steel sheet  
Please observe the article number on the type plate of your machine. The trade names of the individual machines may vary.

## Noise/Vibration Information

Measured values determined according to EN 60745.

Typically the A-weighted sound pressure level of the product is less than 70 dB(A). Uncertainty  $K < 1.5$  dB.

The noise level when working can exceed 80 dB(A).

### Wear hearing protection!

Vibration total values (triax vector sum) determined according to EN 60745:  
Vibration emission value  $a_h = 3.5$  m/s<sup>2</sup>,  
Uncertainty  $K < 1.5$  m/s<sup>2</sup>.

The vibration emission level given in this information sheet has been measured in accordance with a standardised test given in EN 60745 and may be used to compare one tool with another. It may be used for a preliminary assessment of exposure.

The declared vibration emission level represents the main applications of the tool. However if the tool is used for different applications, with different accessories or poorly maintained, the vibration emission may differ. This may significantly increase the exposure level over the total working period.

## 16 | English

An estimation of the level of exposure to vibration should also take into account the times when the tool is switched off or when it is running but not actually doing the job. This may significantly reduce the exposure level over the total working period.

Identify additional safety measures to protect the operator from the effects of vibration such as: maintain the tool and the accessories, keep the hands warm, organisation of work patterns.

### Declaration of Conformity

We declare under our sole responsibility that the product described under "Technical Data" is in conformity with the following standards or standardization documents: EN 60745 according to the provisions of the directives 2004/108/EC, 98/37/EC (until 28 Dec 2009), 2006/42/EC (from 29 Dec 2009).

Technical file at:

Robert Bosch GmbH, PT/ESC,  
D-70745 Leinfelden-Echterdingen

Dr. Egbert Schneider Senior Vice President  
Engineering

Dr. Eckerhard Strötgen  
Head of Product  
Certification

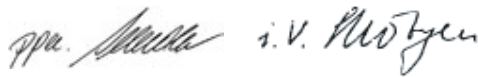

Robert Bosch GmbH, Power Tools Division  
D-70745 Leinfelden-Echterdingen  
Leinfelden, 08.12.2008

## Assembly

### Battery Charging

- **Use only the battery chargers listed on the graphics page.** Only these battery chargers are matched to the lithium ion battery used in your machine.

**Note:** The battery is supplied partially charged. To ensure full capacity of the battery, completely charge the battery in the battery charger before using your power tool for the first time.

The lithium ion battery can be charged at any time without reducing its service life. Interrupting the charging procedure does not damage the battery.

The battery is equipped with a NTC temperature control which allows charging only within a temperature range of between 0 °C and 45 °C. A long battery service life is achieved in this manner.

### Battery Charge-control Indication

The three green LEDs of the battery charge-control indicator **4** indicate the charge condition of the battery **2**. For safety reasons, it is only possible to check the status of the charge condition when the machine is at a standstill.

To indicate the charge condition, press and hold button **3** of the switched off machine.

LED	Capacity
Continuous lighting 3 x green	≥2/3
Continuous lighting 2 x green	≥1/3
Continuous lighting 1 x green	<1/3
Flashing light 1 x green	Reserve

### Removing the Battery

To remove the battery **2**, press the unlocking buttons **1** and pull the battery out of the machine to the rear. **Do not exert any force.**

## Operation

### Starting Operation

#### Inserting the Battery

- **Use only original Bosch lithium ion batteries with the voltage listed on the nameplate of your power tool.** Using other batteries can lead to injuries and pose a fire hazard.

**Note:** Use of batteries not suitable for the machine can lead to malfunctions of or cause damage to the power tool.

Insert the charged battery **2** into the handle until it can be felt to engage and faces flush against the handle.

### Switching On and Off

To **start** the machine, push the On/Off switch **5** forward so that the “**I**” is indicated on the switch.

To **switch off** the machine, push the On/Off switch **5** toward the rear so that the “**0**” is indicated on the switch.

The Li-ion battery is protected against deep discharging by the “Electronic Cell Protection (ECP)”. When the battery is empty, the machine is switched off by means of a protective circuit: The inserted tool no longer rotates.

**Note:** If the machine should automatically switch off because of a discharged or overheated battery, make sure to set the machine’s On/Off switch **5** to off. Charge the battery and allow it to cool down before restarting the machine. Otherwise the battery can become damaged.

### Working Advice

- ▶ **The power tool is not suitable for stationary operation.** For example, it may not be clamped in a vice or fastened on a workbench.
- ▶ **Only work with the chip deflector 6 mounted. Take care that the chip deflector is not damaged or bent.** Danger of injury when working without the chip deflector or when it is damaged. Have a damaged chip deflector replaced immediately by an after-sales service centre for Bosch power tools.
- ▶ **Wear protective gloves while working. Take care that cut sheet parts do not bend toward your body.** Sharp burrs develop at the cut steel sheet and can cause injuries to the operator. If required, press bending steel sheet parts away from your body using gloves.

Apply the power tool to the workpiece only when switched on.

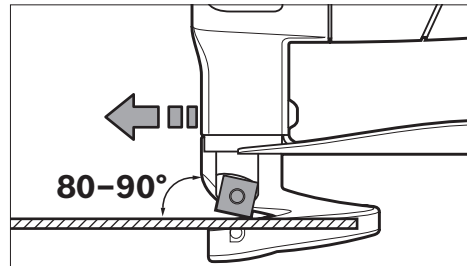

Guide the power tool at an angle of 80 to 90° to the surface of the sheet metal and do not tilt it to the side.

Guide the machine evenly and with light feed in the cutting direction. Excessive feed significantly reduces the service life of the saw blade and can cause damage to the power tool.

When cutting curves, make sure not to tilt the power tool laterally and work with low feed rate only.

### Maximum Steel Sheet Cutting Capacity

The maximum steel sheet cutting capacity  $d_{max}$  depends on the strength properties of the material to be cut.

The machine allows for cutting of metal sheet to the following thicknesses:

Material	Max. strength property [N/mm <sup>2</sup> ]	$d_{max}$ [mm]
Steel	400	1.3
	600	0.8
	800	0.6
Aluminium	250	2.0

### Adjusting Cutter Clearance a

- ▶ **Before any work on the machine itself (e.g. maintenance, tool change, etc.) as well as during transport and storage, remove the battery from the power tool.** There is danger of injury when unintentionally actuating the On/Off switch.

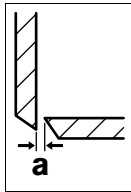

The cutter clearance **a** (gap between the cutters) depends on the sheet thickness  $d_{\max}$  to be cut.

The cutter clearance **a** should be 10 % of the sheet thickness  $d_{\max}$  (e.g. 0.1 mm cutter clearance for 1 mm sheet thickness).

For softer or more ductile materials, the clearance **a** must be decreased; for harder or more brittle materials, increased.

Loosen the fastening screw **12** for the bottom cutter. Adjust the required cutter clearance **a** with the adjustment screw **11**. The upper cutter **9** and the bottom cutter **10** may not touch each other. Check the clearance with the setting gauge **13**. Retighten the fastening screw **12** for the bottom cutter with a tightening torque of 3–4 Nm.

### Temperature Dependent Overload Protection

When using the machine as intended for, it cannot be subject to overload. In case of excessive load or when not within the permitted battery temperature range of 0–70°C, the stroke rate is reduced or the machine switches off. With reduced stroke rate, the machine will not run at full stroke rate again until after reaching the permitted battery temperature. In case of automatic shut-off, switch the machine off, allow the battery to cool down and then switch the machine on again.

### Recommendations for Optimal Handling of the Battery

Protect the battery against moisture and water. Store the battery only within a temperature range between 0 °C and 45 °C. As an example, do not leave the battery in the car in summer.

A significantly reduced working period after charging indicates that the battery is used and must be replaced.

Observe the notes for disposal.

## Maintenance and Service

### Maintenance and Cleaning

- ▶ **Before any work on the machine itself (e.g. maintenance, tool change, etc.) as well as during transport and storage, remove the battery from the power tool.** There is danger of injury when unintentionally actuating the On/Off switch.
- ▶ **For safe and proper working, always keep the machine and ventilation slots clean.**

### Replacing the blade (see figure A)

The upper cutter **9** and the bottom cutter **10** are identical, have four cutting edges each, and can be exchanged with each other.

Turn or replace the cutters in good time. Only sharp application tools achieve good cutting capacity and make the machine last longer.

To replace the upper cutter **9**, loosen the fastening screw **8**; to replace the bottom cutter **10**, loosen the fastening screw **12**.

Turn the cutter by 90° or install a new cutter. When installing the bottom cutter **10**, pay attention that it faces against the adjustment screw **11**.

**Note:** Turn the cutter only in the direction indicated in the figure and insert a new cutter only in the position shown in the figure. Cutting is not possible with an incorrectly inserted cutter.



Retighten the fastening screw **8** for the upper cutter and the fastening screw **12** for the bottom cutter with a tightening torque of 3–4 Nm. Check the cutter clearance **a** (see “Adjusting Cutter Clearance a”, page 18).

Upper cutter **9** and bottom cutter **10** may not be reground.

If the machine should fail despite the care taken in manufacturing and testing procedures, repair should be carried out by an after-sales service centre for Bosch power tools.

In all correspondence and spare parts order, please always include the 10-digit article number given on the type plate of the machine.

### After-sales Service and Customer Assistance

Our after-sales service responds to your questions concerning maintenance and repair of your product as well as spare parts. Exploded views and information on spare parts can also be found under:

**[www.bosch-pt.com](http://www.bosch-pt.com)**

Our customer consultants answer your questions concerning best buy, application and adjustment of products and accessories.

#### Great Britain

Robert Bosch Ltd. (B.S.C.)  
P.O. Box 98  
Broadwater Park  
North Orbital Road  
Denham  
Uxbridge  
UB 9 5HJ  
Tel. Service: +44 (0844) 736 0109  
Fax: +44 (0844) 736 0146  
E-Mail: [SPT-Technical.de@de.bosch.com](mailto:SPT-Technical.de@de.bosch.com)

#### Ireland

Origo Ltd.  
Unit 23 Magna Drive  
Magna Business Park  
City West  
Dublin 24  
Tel. Service: +353 (01) 4 66 67 00  
Fax: +353 (01) 4 66 68 88

### Australia, New Zealand and Pacific Islands

Robert Bosch Australia Pty. Ltd.  
Power Tools  
Locked Bag 66  
Clayton South VIC 3169  
Customer Contact Center  
Inside Australia:  
Phone: +61 (01300) 307 044  
Fax: +61 (01300) 307 045  
Inside New Zealand:  
Phone: +64 (0800) 543 353  
Fax: +64 (0800) 428 570  
Outside AU and NZ:  
Phone: +61 (03) 9541 5555  
[www.bosch.com.au](http://www.bosch.com.au)

### Transport

The battery is tested according to UN document ST/SG/AC.10/11/Rev.3 Part III, subsection 38.3. It has effective protection against internal overpressure and short circuiting as well as devices for the prevention of violent rupture and dangerous reverse current flow.

The lithium-equivalent content in the battery is below applicable limit values. Therefore, the battery is not subject to national or international regulations pertaining to dangerous mediums, neither as an individual component nor when inserted into a machine. However, the regulations governing dangerous goods may be relevant when transporting several batteries. In this case, it can be necessary to comply with special conditions (e.g., concerning the packaging). For more information, please refer to the instruction sheet (in English) under the following Internet address:

<http://purchasing.bosch.com/en/start/Allgemeines/Download/index.htm>

## Disposal

The machine, accessories and packaging should be sorted for environmental-friendly recycling.

### Only for EC countries:



Do not dispose of power tools into household waste!

According the European Guideline 2002/96/EC for Waste Electrical and Electronic Equipment and its implementation into national

right, power tools that are no longer usable must be collected separately and disposed of in an environmentally correct manner.

### Battery packs/batteries:



#### Li-ion:

Please observe the instructions in section "Transport", page 19.

Do not dispose of battery packs/batteries into household waste, fire or water. Battery packs/batteries should be collected, recycled or disposed of in an environmental-friendly manner.

### Only for EC countries:

Defective or dead out battery packs/batteries must be recycled according the guideline 91/157/EEC.

Batteries no longer suitable for use can be directly returned at:

#### Great Britain

Robert Bosch Ltd. (B.S.C.)  
P.O. Box 98  
Broadwater Park  
North Orbital Road  
Denham  
Uxbridge  
UB 9 5HJ  
Tel. Service: +44 (0844) 736 0109  
Fax: +44 (0844) 736 0146  
E-Mail: SPT-Technical.de@de.bosch.com

**Subject to change without notice.**